



TA150

Noise sensor

User Guide

M_TA150_v0008_20251126_EN

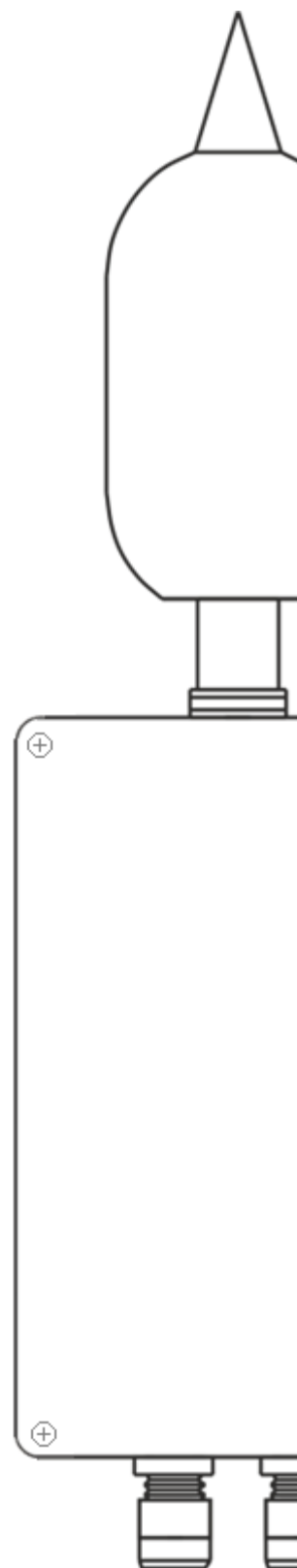

CESVA, founded in 1969 in Barcelona, has always engaged in the manufacturing of sound equipment and instruments with in-house R&D&I and patents.

We belong to national and international committees for the establishment and revision of standards.

CESVA has a fast and efficient distribution network in over 40 countries around the world.

We offer our customers an after-sales service to ensure the long life of our instruments. Periodic tests and calibration services are also available.

Our website is the focal point for finding information on our products, requesting no-obligation quotes, downloading software, contacting us and being kept updated about all the training events and exhibitions we are present at on a regular basis.

Taking care of and listening to our customers brings us closer to them and allows us to provide them with a measuring solution that is totally adapted to their needs.

1. Equipment and literature	4
2. General device description	5
2.1 TA150 Noise Sensor	5
2.2 Key features of the TA150 sensor	6
2.3 Parts of the equipment	7
3. Web server	9
3.1 Accessing the web server	9
3.2 Dashboard	10
3.3 Adjustment	13
3.3.1 Sensitivity adjustment	14
3.3.2 Maintenance	14
3.4 Interface	14
3.4.1 Output interface ⁽³⁾	15
3.4.2 Internet interface	17
3.5 Platform	19
3.5.1 Data registers (Platform for data records)	20
3.5.2 Audio registers (Platform for Audio Files)	27
3.6 Real Time data	32
3.7 To exit the web server	32
4. Installation of the sensor TA150	33
4.1 Steps to follow	33
4.2 Cable gland inputs	36
5. Power supply for the TA150	38
5.1 Mains power	38
5.2 5-12VDC Input	39
5.3 PoE (Power Over Ethernet)	39
5.4 BA150* and BA151* Battery (optional)	40
6. Communication of the TA150 for Data Transmission	41
6.1 Ethernet	42
6.2 Wi-Fi	42
6.3 4G Modem + Geolocation* (MR154)	42

6.4 Current Loop 4-20mA* (optional CL120)	43	
6.4.1 Description of a 4-20mA current loop* circuit	44	
6.5 RS-232* (optional RS152)	45	
6.6 RS-485* (optional RS154)	45	
7. Optional firmware modules*	46	
7.1 FR150 module*	46	
7.2 GA150 Module*	47	
8. Acoustic verification	48	
8.1 Remove the front cover and TK120 outdoor kit	48	
8.2 Place the calibrator	49	
8.3 Verify the adjustment	50	
8.4 Close and secure the sensor	51	
9. Maintenance	52	
9.1 Replacing the windscreen	52	
9.2 Replacing the outdoor kit	55	
9.2.1 Removing the outdoor kit	55	
9.2.2 Installing the outdoor kit	56	
10. Firmware update and module activation	57	
10.1 Firmware update	57	
10.2 Activation of an optional TA150 module	58	
11. Technical specifications	59	
11.1 REFERENCE CONDITIONS	59	
11.2 ACOUSTIC MEASUREMENT ACCORDING TO IEC 61672-1	59	59
11.3 MICROPHONE	61	
11.4 WARM-UP TIME	61	
11.5 AUDIO ACQUISITION	61	
11.6 PROTECTION AGAINST EXTERNAL AGENTS	61	
11.7 CONNECTIVITY	61	
11.8 OPTIONAL CONNECTIVITY	62	
11.9 TRANSMISSION PROTOCOLS	62	
11.10 REMOTE CONTROL	62	
11.11 POWER SUPPLY	63	
11.12 ENVIRONMENTAL CRITERIA	63	
11.13 DIMENSIONS AND WEIGHT	64	
11.14 MARKING	64	
11.15 OPTIONS*	64	
12. Precautions and care for the sensor	65	

Equipment and literature

1

The first step is to check the equipment and literature supplied with the device:

Material included:

- *TA150* noise sensor, consisting of its central body and *TK120* outdoor kit to protect the microphone.
- Connectors for mains power cable and 5-12VDC.
- Cap for input cable gland.

Literature included:

- Quick guide for the *TA150 noise sensor*.
- Warranty

If any of these items are missing, please contact your **CESVA** official distributor.

IMPORTANT: Throughout this manual, modules and options that are not included in the basic configuration of the equipment are mentioned. These are optional and must be purchased separately. These modules/options will be indicated with an asterisk (*).

NOTE: Only one additional module hardware can be added (see section 6). It is important to note that once installed, it cannot be modified.

This chapter provides a general description of the *TA150* noise sensor. This description will allow you to understand all the possibilities offered by the *TA150*, its key features, and identify the various parts that compose it.

2.1 *TA150* Noise Sensor

CESVA takes a step forward in noise level monitoring by designing the new *TA150* sensor, which combines the precision of a Class 1 sound level meter and the detail of a 1/3 octave band spectrum analyser*, while maintaining the ease and simplicity of installation and information retrieval through open-source platforms or industrial protocols.

The *TA150* includes the professional *TK120* outdoor kit, providing maximum protection against external agents (rain, snow, wind, dust, birds).

This new model measures all parameters simultaneously with different frequency and time weightings. Additionally, it provides information in 1/3 octave bands* from 6.3 Hz to 20 kHz to analyse sound events that may occur, including the evaluation of low frequencies.

Its mini-OLED screen provides precise information on the measured level and the status of communications and power supply of the *TA150* from the device itself, without the need for any software.

These features make the *TA150* an ideal device for multiple applications such as infrastructure analysis, industrial analysis, activity monitoring, urban planning, smart tourist destinations, and protection and control of zones (ZARE, ZEPQA, ZPAE, and ZAS).

The *TA150* sensor provides the most convenient and reliable way to remotely monitor and manage noise.

2.2 Key features of the TA150 sensor

The most important features of the *TA150* sensor are as follows:

- Class 1 precision sensor according to IEC 61672-1.
- Mini-OLED screen displaying the status of communications and power supply of the sensor without the need for any software. It also shows the LA1s level in real-time.
- Protection against external agents with the *TK120* outdoor kit: wind, rain, birds. Maintains class 1.
- Fully integrable into different platforms, open source, and sensor connectivity.
- Supports HTTPS and MQTT communication protocols.
- Compact dimensions and easy to install on streetlights, luminaires, bus shelters, MUPIs, OPIs, billboards, and advertising poles.
- Powered by mains, POE (Power over Ethernet), 5-12 VDC (solar panels, external batteries, power banks), public lighting network with daily backup from *BA150** battery and *BA151** battery.
- Continuous measurement 24 hours/7 days a week.
- Equipped with a web server for configuration and adjustment.
- Volatile memory with a capacity of 2 months, with a recording time of 1 minute. Or 30 days if 1 function is also saved every second.
- Measures L_{AT} , L_{CT} , L_{ZT} , L_{AIT} , L_{AFmaxT} , L_{ASmaxT} , L_{AlmaxT} , L_{CpeakT} , L_{ZpeakT} , and optionally $L_{T1/3*}$ (6.3 Hz – 20 kHz).
- Allows obtaining the audio signal acquired by the microphone from the location where the sensor is installed.
- Minimal annual maintenance. The materials used in the manufacture of the *TA150* ensure a long lifecycle. National technical service available.
- Detachable *TK120* outdoor kit for quick verification and adjustment with an acoustic calibrator (IEC 60942).
- The *TA150* sensor has various hardware modules divided into two groups according to their function. On one hand, there are modules for internet connectivity, such as Ethernet (*RJ45*), Wi-Fi, and 4G Modem + Geolocation* (*MR154*). On the other hand, there are modules used for communication with external outputs, such as the current loop* (*CL150*), RS-232* serial (*RS152*), and RS-485* serial (*RS154*).
- To reset the sensor, disconnect the power for a few seconds and then reconnect it.

2.3 Parts of the equipment

1. **TK120 outdoor kit, microphone, and preamplifier** · Kit responsible for protecting the microphone and preamplifier from possible weather factors: wind, snow, rain, etc.
2. **Screws** · 4 screws for closing the front cover of the central body [3].
3. **Central body** · Maintains an IP65 rating when closed. Inside, it contains the elements described between points [6] and [18].
4. **Gland cable input** · For *TA150* communication.
5. **Gland cable input** · For *TA150* power supply.
6. **USB connector** · Type B connector for technical service.
7. **LAN connector** · Connector for Ethernet connection.
8. **Option serial number*** · The serial number of the installed option (4-20mA current loop*, 4G modem*, *RS-232** or *RS-485**).
9. **Connector for 4-20 mA current loop* / RS-232* / RS-485* / SIM card slot*** · If one of these options has been purchased.
10. **Marks** · CE mark (European Conformity Mark) and WEEE mark (indicates selective collection of electrical/electronic equipment).
11. **Equipment information** · Model and serial number of the *TA150*.
12. **Mini-OLED screen** · Displays sensor information.
13. **Button** · To change the screen or activate/deactivate the web server mode.
14. **Battery support for BA150* and BA151***.
15. **Information of terminal blocks for power supply** [16] and [17].
16. **Connector for 5-12VDC power supply** · Terminal block for 5-12V power supply via external battery, power banks, USB chargers, etc.
17. **Connector for mains power supply:** · Terminal block for 100-240V~ 50/60Hz mains power supply.
18. **Information of terminal block for connecting the battery.**
19. **Connector for battery (BA150* and BA151*)** · Terminal block for connecting the battery.

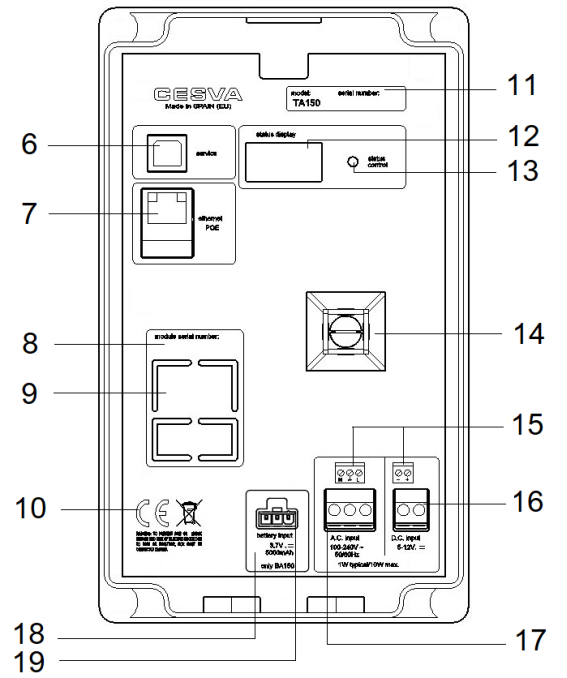
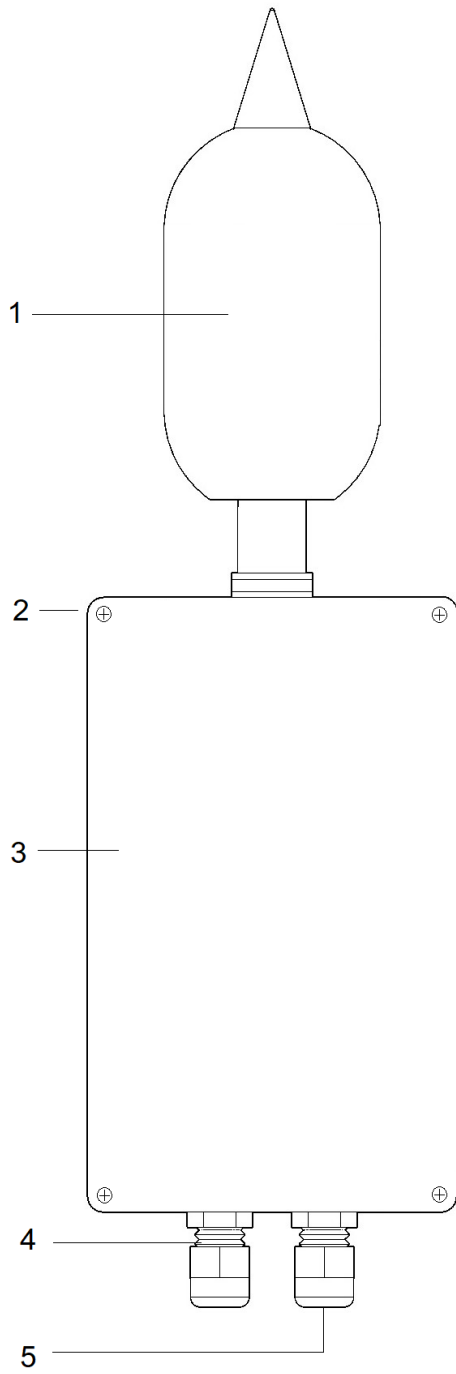

The *TA150* has an internal memory where its configuration is stored. To configure the sensor, you must access it via the web server. The web server also allows you to view the measured levels and adjust the sensor's sensitivity. Additionally, it shows a history of all adjustments and changes made.

Access to the web server is achieved by activating the "web server mode" of the *TA150* (see section 3.1) and accessing it with an external device that has a web browser: desktop computer, laptop, tablet, smartphone, etc.

NOTE: While the sensor is connected to the web server, the data is stored in the sensor's memory ⁽¹⁾. The sensor does not send data over the internet to any platform until the web server mode is deactivated (see section 3.7). However, if the sensor has any communication module for external outputs (*CL150**, *RS154** (RS-485) or *RS152** (RS-232)) the data continues to be sent even if the web server mode is activated.

⁽¹⁾ The sensor must have the date and time stored internally (see section 4.1)

3.1 Accessing the web server

To access the web server, follow these steps:

1. Ensure that the *TA150* sensor is turned on (if not, power the sensor as described in chapter 5).
2. Ensure that the mini-OLED screen is on (if not, press the button [13] once).
3. Activate the web server mode of the *TA150*:
 - Press and hold the button [13] until the progress bar completes and the following information appears on the screen:
 - 
 - *TA150* and the serial number
 - Password for the Wi-Fi generated by the *TA150*
 - IP address to access the web server

When the web server communication mode of the *TA150* is activated, it generates an access point (Wi-Fi wireless communication network).

From this moment, you can access to the web server.

4. From the PC or device you want to use to access the web server, search for the Wi-Fi network generated by the *TA150* and connect it.

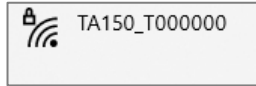

(The first time you connect it, it will ask for the password shown on the sensor's screen).

5. Open the Internet browser and enter the IP address (Wi-Fi) shown on the *TA150* sensor's screen (192.168.60.100) in the address bar.
6. Once inside the web server, all the information about the *TA150* sensor will appear.
7. At the top, a menu with the different available options will be shown:
 - Dashboard
 - Adjustment
 - Interface
 - Platform (Data, Audio)
 - Real time

To access each of them, simply click on the name with the mouse, and the corresponding screen will automatically appear.

NOTE: The web server is displayed in English. To change the language, you can use the default translator for browsers such as Google Chrome, Mozilla Firefox, or Microsoft Edge.

3.2 Dashboard

On this screen, all information regarding the configuration of the *TA150* sensor is displayed.

Sensor information

- General information
 - Model
 - Serial number
 - Firmware: Firmware version

- Log

By clicking on the icon  **Log**, a history of the various changes made to the sensor (firmware updates and sensitivity adjustments) appears.

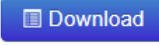
It also allows downloading the history file in CSV format. To obtain it, simply click the button .

- Hardware modules (**Installed** and **Not installed**):

(only one optional (*) hardware module can be installed)

- Wi-Fi
 - 4G Modem*
 - 4-20 mA*
 - RS-232*
 - RS-485*
 - Battery*: If installed, click on the icon  to select the installed battery model from the dropdown menu (see battery model).
- Firmware modules (**Installed** and **Not installed**):
 - SLM: Sound level meter
 - 1/3 filters*: 1/3 octave band spectral analysis.
 - Audio*: Acquisition of audio files captured by the microphone.

Seor Status

- External output modules (only available if the TA150 has one of these modules 4-20 mA, RS-232, or RS-485*)
 - Type: 4-20 mA*, RS-232* or RS-485*
 - Protocol:
 - 4-20 mA*: (Disabled or CESVA)
 - RS-232*: (Disabled, CESVA or Modbus)
 - RS-485*: (Disabled, CESVA, Modbus (2-wire) or Modbus (4-wire))
- Internet Interface (Interface and features):
 - Ethernet: MAC address and DHCP
 - Wi-Fi: Wi-Fi network name and coverage (*if the 4G Modem*, Current Loop*, RS-232* or RS-485* modules are not installed*).



- 4G Modem*: Network type, modem coverage, SMS **ON** (SMS notifications are enabled), SMS **OFF** (SMS notifications are not enabled) (see 3.4.2 and 3.4.2.3).
 - Current Loop*: Selected internet interface.
 - RS-232*: Selected internet interface.
 - RS-485*: Selected internet interface.
- Power supply
 - Mains power: 100-240 V
 - 5-12 VDC input
 - Ethernet POE
 - Battery*: Approximate battery charge level ⁽²⁾ (when battery is installed) or **Not installed** when the battery is not installed.

⁽²⁾ The battery charge indicator takes time to adjust after the sensor has been disconnected from the mains.
- Maintenance:
 - Last sensor verification: Date of the last recorded sensor verification. If not yet done, it shows "Not registered".
 - Last windscreen foam change: Date of the last recorded windscreen foam change. If not yet done, it shows "Not registered".



Internet data transmission



- Sensor time





If the sensor time is already synchronized:

- **Time sincronized**: The time is set.
- Date, time and time zone.
- : To manually synchronize the sensor time with the user's external device (PC, Tablet), click , then
 - click **Update** to apply the time synchronization.
 - or click **Close** to discard.

If the sensor time is not synchronized

- **Time not set**: The time is not set.
- ?? UTC: The sensor has not an UTC value assigned.
- : To manually synchronize the sensor time with the user's external device (PC, Tablet), click , then

- click  to apply the time synchronization.
 - or click  to discard it.

- Platform configuration:
 - Protocol
 - HTTP
 - HTTPS
 - MQTT/TLP
 - MQTT/TLS
 - Platform:
 - CESVA
 - Sentilo
 - UltraLight 2.0
 - Generic JSON
 - 1-second function*
 - activated  (if activated, shows the selected 1-second function)
 - or deactivated 
 - 1/3 octave spectrum analysis recording*
 - Activated 
 - deactivated 
 - or module not installed 

- Memory buffer:
 - % of the memory buffer that is occupied or  if it is empty.



(NOTE: If the sensor is unpowered, the data will be erased from the buffer)

3.3 Adjustment

This screen allows you to adjust the sensitivity level of the *TA150*, save the date of the last verification of the sensor's measured level, or save the date of the last change of the outdoor kit foam.

3.3.1 Sensitivity adjustment

To adjust the sensitivity of the *TA150*:

- With the calibrator already placed as indicated in section 8.2, check the level displayed on the screen (see section 8.3 point 3. Ideally, it should show a level of 93.9 dB. If not, the following actions should be taken:
 - If the deviation is not greater than 0.5 dB, the verification is correct, and no action is needed.
 - If the deviation is greater than 0.5 dB but not greater than 1 dB, no action is needed, but we recommend keeping the *TA150* under observation until the next verification. If it remains within the range during the next verification, readjust the sensitivity using the adjustment buttons  . As the adjustment buttons are pressed, the level variation from the initial level (before starting the adjustment) is displayed. Once the value of 93.9 dB is obtained, press the  button to apply the adjustment.
 - If the deviation is greater than 1.0 dB, the *TA150* should be sent to CESVA technical service.
- Turn off the calibrator and carefully remove it from the sensor (see section 8.4).
- Carefully insert the *TK120* outdoor kit without damaging the microphone. Screw to the left using the base of the kit (see section 8.4).

3.3.2 Maintenance

In the Maintenance section:

- To record the last verification of the sensor's measured level, access:

Last sensor check and press the button 

- To record the last time the outdoor kit foam was replaced, access:

Last foam change and press the button 

To download the CSV file with the information of the last sensitivity adjustment made, click on the icon  located at the bottom right.

3.4 Interface

This screen shows information regarding:

- The external output interface ⁽³⁾
- The internet interface

Additionally, it allows adjusting this information according to the user's needs.

⁽³⁾ Information about the external output interface is only available if the *TA150* has one of the following modules installed: Current Loop*, RS-232* or RS-485*. Otherwise, only information regarding the internet interface will appear.



NOTE: The frequency at which functions are sent via the external output (Current Loop*, RS-232* or RS-485*) is independent of the frequency at which functions and audio are sent to the internet (Ethernet, Wi-Fi, Modem).

3.4.1 Output interface ⁽³⁾

The output interface will only appear if the *TA150* sensor has the current loop*, RS-232* or RS-485* module installed. The information displayed is:

- The installed output interface
- The selected protocol
- And the protocol configuration

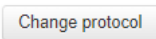
To modify the protocol:

- Press the  button .
- Select the desired option from the dropdown menu.
- Finally, press  to save the change or press  to discard it.

The available protocols will depend on the installed module:

- Current Loop*
 - Disabled
 - CESVA
- RS-232*
 - Disabled
 - CESVA
 - Modbus

- RS-485*
 - Disabled
 - CESVA
 - Modbus (2-wire)
 - Modbus (4-wire)

3.4.1.1 Current loop* (optional)

The parameters to configure depends on the selected protocol.

- **Disabled:** No parameters need to be configured as the option will be disabled.
- **CESVA Protocol:** Detailed information about the parameters of this protocol is shown in the protocol document.

3.4.1.2 RS-232* (optional)

The parameters to configure depends on the selected protocol:

- **Disabled:** No parameters need to be configured as the option will be disabled.
- **CESVA Protocol:** Detailed information about the parameters of this protocol is shown in the protocol document.
- **Modbus Protocol:** Detailed information about the parameters of this protocol is shown in the protocol document.

3.4.1.3 RS-485* (optional)

The parameters to configure depends on the selected protocol.

- **Disabled:** No parameters need to be configured as the option will be disabled.
- **CESVA Protocol:** Detailed information about the parameters of this protocol is shown in the protocol document.
- **Modbus Protocol (2-wire):** Detailed information about the parameters of this protocol is shown in the protocol document.
- **Modbus Protocol (4-wire):** Detailed information about the parameters of this protocol is shown in the protocol document

3.4.2 Internet interface

The following information will be displayed:

- The selected internet interface
- The parameters of the selected interface



The available interfaces are:

- Disabled
- Ethernet
- Wi-Fi 2.4 GHz
- 4G Modem* (*only available if the TA150 has the 4G modem* installed*)

IMPORTANT NOTE: The TA150's data usage depends on multiple factors. These include: coverage (GPRS, 3G, 4G), the number of parameters sent (global levels, frequency levels in the 1/3 octave band), the frequency at which the information is obtained (1 m, 1 s), the transmission protocol used (Ultralight, JSON, etc.), etc.

For this reason, if you plan to use the 4G Modem interface for data sending, it is recommended to purchase a flat-rate 4G SIM card with a minimum of 1 GB. This recommendation does not consider the possible use of optional modules such as audio recording or the option to send SMS Notifications, whose activation conditions could generate a significant additional volume of data and costs).

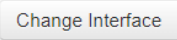
To modify the interface:

- Press the  button
- Select the desired option from the dropdown menu.
- Finally, press  to save the change or press  to discard it.

The parameters to configure depends on the selected interface.

3.4.2.1 Ethernet Interface

The following information will be displayed:

- The selected interface type
- The MAC address

The only parameter that needs to be configured when the interface is Ethernet is DHCP (Dynamic Host Configuration Protocol):



- To have a dynamic IP, select "Yes" in the DHCP dropdown menu, or select "No" if a static IP is desired.
- Finally, press the  button.

3.4.2.2 Wi-Fi 2.4 GHz Interface

The following information will be displayed:

- The selected interface type
- The MAC address
- Wi-Fi network coverage

To configure the Wi-Fi interface parameters:

- Press the  button
- All available Wi-Fi networks along with their coverage % will automatically be displayed.
- Select the desired Wi-Fi network, which will fill in the SSID field.
- Then, enter the corresponding password for the selected network in the Password field.
- In the DHCP dropdown menu (Dynamic Host Configuration Protocol), select "Yes" for a dynamic IP or "No" for a static IP.
- Finally, press the  button.

3.4.2.3 4G Modem interface* (optional)

The 4G Modem interface* is only available if the *TA150* has the 4G Modem module installed.

Before using the 4G Modem interface, read the **IMPORTANT NOTE** in section 3.4.2.

The following information will be displayed:

- The selected interface type
- The IMEI
- Modem coverage
- Geolocation coordinates

To configure the 4G Modem interface*, enter the following parameters:

- SIM card PIN (press  to view values)
- APN of the telecom company
- User of the telecom company
- Password of the telecom company

SMS Notifications:

The sensor has a configurable automatism system to receive SMS notifications. These automatisms are based on several parameters and serve to indicate the conditions under which these notifications will be received. The system allows you to configure up to 3 independent automatizations. Giving priority to the automation that is fulfilled first (Notification trigger 1, Notification trigger 2 and Notification trigger 3).

The parameters that must be configured are:

- Mobile number: The mobile phone number on which you want to receive SMS notifications.
- Language: Language of the text of the notifications.
- Consecutive registers: The number of consecutive records during which the conditions configured in the notification trigger (Notification trigger 1, Notification trigger 2, or Notification trigger 3) must be met.
- Message example: Example of the text of the notifications that will be sent by SMS.
- Notification trigger 1:
 - Trigger mode: Using the drop-down menu, select the trigger mode. The available options are:
 - On: SMS notification sent enabled.
 - Off: SMS notification sending disabled.
 - Interval: Select the interval (hh:mm start and hh:mm end) during which it is desired to receive the SMS notifications. To receive them 24 hours a day, press the  button.
 - Trigger function: Select the function that will compare its levels with the indicated threshold level.
 - Threshold level: Indicate the threshold level in dB, which is taken as a reference.

The other two notification triggers (Notification trigger 2 and Notification trigger 3) will be configured in the same way.

- Finally, press the button .

3.5 Platform

This screen shows information regarding:

- The Data Platform (Data register)
- The Audio Platform⁽⁴⁾ (Audio register)

Additionally, it allows adjusting the information according to the user's chosen platform.





⁽⁴⁾ Information about the Audio Platform* is only available if the *TA150* has the Audio firmware module installed (see section 3.2). Otherwise, only information regarding the Data Platform will appear.

NOTE: The frequency at which functions are sent via the external output (Current Loop*, RS-232* or RS-485*) is independent of the frequency at which functions and audio files* are sent to the internet (Ethernet, Wi-Fi, Modem).

3.5.1 Data registers (Platform for data records)

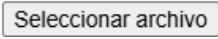

This screen allows selecting the platform through which the sensor data will be obtained and configuring various parameters.

It also allows importing or exporting the platform configuration to save the user's time. To do this, press , and the following screen will automatically be opened:

- To export the platform configuration file, go to the **Export** tab and press . Finally, press .
- To import the platform configuration file, go to the **Import** tab and press , then select the (.conf) file to be imported. Finally, press .

At the top of the screen, the currently selected platform is displayed.

To change the platform:

- Press the  button.
- Select the desired option from the dropdown menu.
- Finally, press  to save the change or press  to discard it.

The available options are:

1. CESVA
2. Generic JSON
3. Sentilo
4. Ultralight 2.0
5. TA120 version: Sentilo
6. TA120 version: UL2.0

A message is displayed indicating that the information shown corresponds to the parameters of the selected platform. Any other information regarding the internet

connection or server status will be displayed on the sensor screen once it has exited the web server.

i This information shows the interface's parameters. Internet connection and the server status will be shown on the sensor's display once you have disconnected the webserver.

Depending on the selected platform, various parameters should be configured.

3.5.1.1 CESVA

When CESVA is selected, the following information is displayed at the top of the screen:

- The selected platform

The CESVA platform is already preconfigured.

3.5.1.2 Sentilo

When Sentilo is selected, the following information is displayed at the top of the screen:

- The selected platform

Next, to configure the Sentilo platform, select the desired communication protocol and enter the corresponding protocol's parameters:

- HTTP Protocol
 - Host
 - Port
 - Provider ID
 - Token
- HTTPS Protocol
 - Host
 - Port
 - Provider ID
 - Token
- MQTT/TCP Protocol
 - Host
 - Port
 - Client ID
 - Username

- Password
- Topic
- MQTT/TLS Protocol
 - Host
 - Port
 - Client ID
 - Username
 - Password
 - Topic

Also, select the parameters you want to receive through the platform:

- Averaging time/Send time: Using the dropdown menu, select the integration time (T) to obtain the equivalent level. This time will also correspond to how often the selected parameters are sent to the platform via the internet. Between 1s and 60 min.
The start of the recording will depend on the selected integration time, as shown in the example below.

Example:

Current time	Averaging time T	Start of Recording
11:01:03	1 s	11:01:03
	5 s	11:01:05
	10 s	11:01:10
	15 s	11:01:15
	30 s	11:01:30
	1 min	11:02:00
	5 min	11:05:00
	10 min	11:10:00
	15 min	11:15:00
	30 min	11:30:00
	60 min	12:00:00

If a time of 10 seconds or less is selected, a message will appear recommending communication via Ethernet to avoid data jams.

⚠ At time 10s or less, we recommend using only the Ethernet interface to avoid data jams

NOTE: This time also represents the periodicity at which audio files* will be sent to the audio platform⁽⁴⁾.

- Minimum sent registers: Using the dropdown menu, select the number of records to be sent each time. The approximate periodicity at which the records will be sent will then appear.

- Send main function: The L_{AT} function will be sent by default. If you want to send the Overload and Underrange parameters corresponding to the L_{AT} function, select "Yes"; otherwise, select "No".
- Send Overall functions: To select the functions to be sent to the platform, mark "Yes" for the corresponding function; otherwise, mark "No". The available functions are (L_{CT} , L_{ZT} , L_{AIT} , L_{AFmaxT} , L_{ASmaxT} , L_{AlmaxT} , L_{Cpeak} , L_{Zpeak} , L_{10T} , L_{50T} y L_{90T}). Also, proceed in the same way to select whether to send the Overload and Underrange parameters corresponding to the selected functions.
- Send 1/3 octave band functions*: To indicate that you want to send the L_T function in 1/3 octave band to the platform, mark "Yes", otherwise, mark "No". Proceed in the same way for the Overload and Underrange parameters.
- L_{1s} registers: To indicate that you want to send a function every second, mark "Yes" and then select the function from the dropdown menu "Select function". The available functions are (L_{A1s} , L_{C1s} , L_{Z1s} , L_{Al1s} , $L_{AFmax1s}$, $L_{ASmax1s}$, $L_{Almax1s}$, $L_{Cpeak1s}$ y $L_{Zpeak1s}$). Proceed in the same way for the Overload and Underrange parameters.

Finally, save the configuration and function selection by pressing the button



3.5.1.3 UltraLight 2.0

When UltraLight 2.0 is selected, the following is displayed at the top of the screen:

- The selected platform.

Next, to configure the UltraLight 2.0 platform, select the desired communication protocol and enter the corresponding protocol parameters:

- HTTP Protocol
 - Host
 - Port
 - Provider ID
 - Token
- HTTPS Protocol
 - Host
 - Port
 - Provider ID
 - Token
- MQTT/TCP Protocol
 - Host
 - Port
 - Client ID
 - Username

- Password
- Topic
- MQTT/TLS Protocol
 - Host
 - Port
 - Client ID
 - Username
 - Password
 - Topic

Also, select the parameters you want to receive through the platform:

- Averaging time/Send time: Using the dropdown menu, select the integration time (T) to obtain the equivalent level. This time will also correspond to how often the selected parameters are sent to the platform via the internet. ($T_{L_{eq}}$ between 1s and 60 min).

The start of the recording will depend on the selected integration time (see Averaging time/Send time in section 3.5.1.2).

If a time of 10 seconds or less is selected, a message will appear recommending communication via Ethernet to avoid data jams.

⚠ At time 10s or less, we recommend using only the Ethernet interface to avoid data jams

NOTE: This time also represents the periodicity at which audio files* will be sent to the audio platform⁽⁴⁾.

- Minimum sent registers: Using the dropdown menu, select the number of records to be sent each time. The approximate periodicity at which the records will be sent will then appear.
- Send main function: The L_{AT} function will be sent by default. If you want to send the Overload and Underrange parameters corresponding to the L_{AT} function, select "Yes"; otherwise, select "No".
- Send Overall functions: To select the functions to be sent to the platform, mark "Yes" for the corresponding function; otherwise, mark "No". The available functions are (L_{CT} , L_{ZT} , L_{AIT} , L_{AFmaxT} , L_{ASmaxT} , L_{AlmaxT} , L_{Cpeak} , L_{Zpeak} , L_{10T} , L_{50T} y L_{90T}). Also, proceed in the same way to select whether to send the Overload and Underrange parameters corresponding to the selected functions.
- Send 1/3 octave band functions*: To indicate that you want to send the L_T function in 1/3 octave band to the platform, mark "Yes"; otherwise, mark "No". Proceed in the same way for the Overload and Underrange parameters.

- L_{1s} registers: To indicate that you want to send a function every second, mark "Yes" and then select the function from the dropdown menu "Select function". The available functions are (L_{A1s} , L_{C1s} , L_{Z1s} , L_{A1s} , $L_{AFmax1s}$, $L_{ASmax1s}$, $L_{Almax1s}$, $L_{Cpeak1s}$ y $L_{Zpeak1s}$). Proceed in the same way for the Overload and Underrange parameters.

Finally, save the configuration and function selection by pressing the button

Save

3.5.1.4 Generic JSON

When Generic JSON is selected, the following is displayed at the top of the screen:

- The selected platform

Next, to configure the Generic JSON platform, select the desired communication protocol and enter the corresponding protocol parameters:

- HTTP Protocol
 - Host
 - Port
 - Provider ID
 - Token
- HTTPS Protocol
 - Host
 - Port
 - Provider ID
 - Token
- MQTT/TCP Protocol
 - Host
 - Port
 - Client ID
 - Username
 - Password
 - Topic
- MQTT/TLS Protocol
 - Host
 - Port
 - Client ID
 - Username
 - Password
 - Topic

Also, select the parameters you want to receive through the platform:

- Averaging time/Send time: Using the dropdown menu, select the integration time (T) to obtain the equivalent level. This time will also correspond to how often the selected parameters are sent to the platform via the internet. ($T_{L_{eq}}$ between 1s and 60 min).

The start of the recording will depend on the selected integration time (see Averaging time/Send time in section 3.5.1.2).

If a time of 10 seconds or less is selected, a message will appear recommending communication via Ethernet to avoid data jams.

 At time 10s or less, we recommend using only the Ethernet interface to avoid data jams

NOTE: This time also represents the periodicity at which audio files* will be sent to the audio platform⁽⁴⁾.

- Minimum sent registers: Using the dropdown menu, select the number of records to be sent each time. The approximate periodicity at which the records will be sent will then appear.
- Send main function: The L_{AT} function will be sent by default. If you want to send the Overload and Underrange parameters corresponding to the L_{AT} function, select "Yes"; otherwise, select "No".
- Send Overall functions: To select the functions to be sent to the platform, mark "Yes" for the corresponding function; otherwise, mark "No". The available functions are (L_{CT} , L_{ZT} , L_{AIT} , L_{AFmaxT} , L_{ASmaxT} , L_{AlmaxT} , L_{Cpeak} , L_{Zpeak} , L_{10T} , L_{50T} y L_{90T}). Also, proceed in the same way to select whether to send the Overload and Underrange parameters corresponding to the selected functions.
- To indicate that you want to send the LT function in 1/3 octave band to the platform, mark "Yes"; otherwise, mark "No". Proceed in the same way for the Overload and Underrange parameters.
- L_{1s} registers: To indicate that you want to send a function every second, mark "Yes" and then select the function from the dropdown menu "Select function". The available functions are (L_{A1s} , L_{C1s} , L_{Z1s} , L_{Al1s} , $L_{AFmax1s}$, $L_{ASmax1s}$, $L_{Almax1s}$, $L_{Cpeak1s}$ y $L_{Zpeak1s}$). Proceed in the same way for the Overload and Underrange parameters.

Finally, save the configuration and function selection by pressing the button

Save



3.5.2 Audio registers (Platform for Audio Files)

When accessing the audio register screen, a DISCLAIMER ⁽⁵⁾ is displayed indicating that:







“Audio capture may involve the processing of information by the device that, depending on local regulations, may be considered personal data.

The client agrees to implement the actions that audio capture may have in its local data protection regulations, releasing CESVA INSTRUMENTS, SLU from all liability.”

⁽⁵⁾ The DISCLAIMER is displayed each time the Audio Registers screen is accessed and the GA150* module has audio acquisition disabled. The GA150* module comes with audio acquisition disabled by default.

If the user does not agree with the disclaimer, they should change the screen without pressing , and the sensor will not record audio. However, if the user agrees with the disclaimer, they should press  and the screen will automatically display the platform selection for obtaining audio files acquired by the sensor and configuring various parameters.

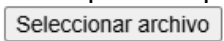
It also allows importing or exporting the platform configuration to save the user's time. To do this, press , and the following screen will automatically open:

- To export the platform configuration file, go to the  **Export** tab and press . Finally, press .
- To import the platform configuration file, go to the  **Import** tab and press , then select the (.conf) file to be imported. Finally, press .

At the top of the screen, the platform is displayed.

3.5.2.1 Custom

The following information is displayed at the top of the screen:

- The platform

Next, to configure the Custom platform, select the desired communication protocol and enter the corresponding protocol parameters:

- HTTP Protocol
 - Host
 - Port

- Path
- Token
- HTTPS Protocol
 - Host
 - Port
 - Provider ID
 - Token

Also, configure the audio files to be obtained:

- Audio file format: Using the dropdown menu, select the audio file format
 - MP3
 - FLAC
 - WAV (only available with Ethernet communication)
- Averaging time/Send time (configured in the Data Platform, see section 3.5.1)
- Audio recording scale: Musing the dropdown menu, select the desired audio scale
 - Between 0 and 77 dB
 - Between 0 and 107 dB
 - Between 0 and 137 dB

The *TA150* has a system of configurable automatisms to indicate the start and end of audio acquisition. These are based on timers and automatic triggers by schedule, level, or emergency. The system allows configuring up to 3 independent automatisms, prioritizing Audio trigger 1, followed by Audio trigger 2, and finally Audio trigger 3.

Each of these automatisms (Auto triggers) has the following configuration parameters:

- Trigger mode: Using the dropdown menu, select the trigger mode. The available options are:
 - **Off**: Audio acquisition disabled
 - **Continuous**: Continuous audio acquisition
 - **By time**: Audio acquisition by time
 - **By level**: Audio acquisition by level
 - **By emergence**: Audio acquisition by exceeding the emergency level + background noise level.

Depending on the selected trigger mode, different parameters will appear:

- **Continuous:**

- Interval: Select the interval (start hh:mm and end hh:mm) during which audio acquisition is desired.

If the start and end times are the same, audio will be acquired for 24 hours.

- 24 h: Select this box to acquire audio continuously for 24 hours.

EXAMPLE: If the configuration is

Averaging time/ Send time = 1 min

Interval = 10:00 – 10:10

10 audio files of 1' will be obtained, one per minute, from 10:01 to 10:10.

Time	10:01	10:02	10:03	10:04	10:05	10:06	10:07	10:08	10:09	10:10
Audio	1'	1'	1'	1'	1'	1'	1'	1'	1'	1'

<input checked="" type="checkbox"/>	Audio files obtained
<input type="checkbox"/>	No audio files obtained

- **By time:**

- Interval: Select the interval (start hh:mm and end hh:mm) during which audio acquisition is desired (without conditions).

If the start and end times are the same, audio will be acquired for 24 hours.

- 24 h: Select this box to acquire audio continuously for 24 hours.
- Sampling period: Indicate the periodicity at which audio files will be obtained.

EXAMPLE: If the configuration is



Averaging time/ Send time = 1 min

Interval = 10:00 – 10:10

Sampling period = 005 (1 of every 5)

The audio file from 10:01 and 10:06 will be obtained.

Time	10:01	10:02	10:03	10:04	10:05	10:06	10:07	10:08	10:09	10:10
Audio	1'	1'	1'	1'	1'	1'	1'	1'	1'	1'

	Audio files obtained
	No audio files obtained

- **By level:**

- Interval: Select the interval (start hh:mm and end hh:mm) during which audio acquisition is desired.

If the start and end times are the same, audio will be acquired for 24 hours.

- 24 h: Select this box to acquire audio continuously for 24 hours.
- Trigger function: Select the function whose levels will be compared with the indicated threshold level.
- Threshold level: Indicate the threshold level in dB, which will be used as a reference.
- Activation mode: Indicate how the audio file acquisition will be activated based on the threshold level.
 - Exceedance: Audio acquisition will be activated when the selected function's level exceeds the threshold level (and the start trigger duration is met).
 - Fall: Audio acquisition will be activated when the selected function's level is below the threshold level (and the stop trigger duration is met).
- Start trigger duration: Indicate the time during which the activation mode condition must be maintained to start audio file acquisition.
- Stop trigger duration: Indicate the time during which the activation mode condition must be maintained to stop audio file acquisition.

EXAMPLE: If the configuration is

Averaging time/ Send time = 1 min

Interval = 10:00 – 10:10

Trigger function = LA1s

Threshold level = 80 dB

Activation mode = Exceedance

Start trigger duration = 05 s

Audio files will be obtained from 10:04 to 10:10.

Time	10:01	10:02	10:03	10:04	10:05	10:06	10:07	10:08	10:09	10:10
LA1s	78,3	77,2	75,5	80,1	81,3	81,2	85,1	80,5	83,2	83,3
Audio	1'	1'	1'	1'	1'	1'	1'	1'	1'	1'

<input checked="" type="checkbox"/>	Audio files obtained
<input type="checkbox"/>	No audio files obtained

- **By emergence:**

- Interval: Select the interval (start hh:mm and end hh:mm) during which audio acquisition is desired.

If the start and end times are the same, audio will be acquired for 24 hours.

- 24 h: Select this box to acquire audio continuously for 24 hours.
- Trigger function: Select the function to be compared with the background noise level to obtain audio files.
- Background function: Select the function representing the background noise level to obtain audio files.
- Emergence range: Indicate the maximum difference in dB between the Background function and the Trigger function from which audio files will be obtained (and the Start trigger duration is met).
- Start trigger duration: Time during which the activation mode condition must be maintained to start audio file acquisition.
- Stop trigger duration: Time during which the activation mode condition must be maintained to stop audio file acquisition.

EXAMPLE: If the configuration is

Averaging time/ Send time = 1 min

Interval = 10:00 – 10:10

Trigger function = LA1s

Background function = L90T

Emergence range = 10 dB

Activation mode = Exceedance

Start trigger duration = 03 s

Audio files from 10:01 to 10:06 will be obtained.

Time	10:01	10:02	10:03	10:04	10:05	10:06	10:07	10:08	10:09	10:10
LA1s	78,3	77,2	75,5	80,1	81,3	81,2	85,1	80,5	83,2	83,3
L90T	68	62,7	54,5	58,1	60,4	69,1	75,9	74,8	75,7	75,1
Audio	1'	1'	1'	1'	1'	1'	1'	1'	1'	1'

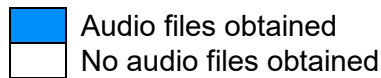

Finally, save the configuration by pressing the  button..

3.6 Real Time data

This screen displays the numerical value of the following functions:

L_{AT} , L_{CT} , L_{ZT} , L_{AIT} , L_{AFmaxT} , L_{ASmaxT} , L_{AlmaxT} , L_{CpeakT} , L_{ZpeakT} and

$L_{T1/3}^*$ (6.3 Hz – 20k Hz).

These can be viewed with an integration time of 1 second by clicking on the [TLeq = 1s](#) tab or 10 seconds by clicking on the [TLeq = 10s](#) tab .

This screen is designed for laboratories to perform the relevant checks.

3.7 To exit the web server

To exit the web server, deactivate the web server mode of the *TA150* by pressing the button [13] until the progress bar completes and the sensor indicators screen appears.

The *TA150* automatically deactivates from web server mode after 60 minutes of inactivity.

4.1 Steps to follow













1. Preferably, mount the sensor vertically using its support and flanges. However, the support also allows for horizontal mounting.







2. Unscrew the 4 screws [1] on the front of the sensor case and remove the cover.



3. Power the *TA150* sensor (see chapter 5).
4. Verify that the sensor screen has turned on. If not, there is a power issue with the equipment; check for external power supply.
5. Configure the *TA150* communication for data transmission (see chapter 6).
6. Wait a few seconds and verify that the indicators on the screen are correct:

Indicator	Description
	Router access is correct (Connected via Ethernet or Wi-Fi).
	Mobile operator access is correct (Connected via Modem*).
	There is an issue with router or mobile operator access.
	There is an issue with internet access.
	Platform access is correct.
	There is an issue with platform access.
	Ethernet communication.
	Wi-Fi communication and Wi-Fi coverage (%).
	Modem* communication and network coverage to which the modem* is connected (%).
 ⁽⁶⁾	The sensor has date and time. NOTE: If the clock does not appear, the sensor does not have date and time.
4G, GPRS...	Network to which it is connected ⁽⁷⁾ .
C. Loop	Transmission via current loop (4-20 mA)*.
RS-232	Transmission via RS-232* serial port.
RS-485	Transmission via RS-485* serial port.
	No BA150* or BA151* battery.
	BA150* or BA151* battery connected.
	BA150* or BA151* battery connected and charging.

XX% XX: (0-100)	The current battery ⁽⁸⁾ charge level, expressed as a percentage. (This always appears next to the  or  indicator).
 AC	Connected to mains power.
 DC	Connected to 5-12 VDC power.
 POE	Connected via POE.

⁽⁶⁾ For the sensor to save measurements in memory and send them to the selected platform, it must first obtain the date and time. The ways the sensor can obtain the date and time are:

- Automatic synchronization when connected to the internet.
- Automatic synchronization when connected to the platform where the data will be sent.
- Manual synchronization via the Dashboard option of the web server (see section 3.2).

⁽⁷⁾ If the *TA150* has an *MR154** modem module installed, the screen will indicate the name of the network to which it is connected at any given time (4G, 4G+, 3G, 3G+).

⁽⁸⁾ The battery charge level indicator takes time to adjust after connecting the battery or restoring power with the battery connected.

If any indicator shows an error, consult with the installer or router/AP provider.

If the indicators are correct, close the sensor case, ensuring it is secured with the 4 screws [1] on the front cover.



4.2 Cable gland inputs

At the bottom of the *TA150*, there are two cable gland inputs[4 y 5] for inserting the necessary cables to power the sensor and for its communication if needed (depending on its configuration).

The gland connector consists of the following elements:

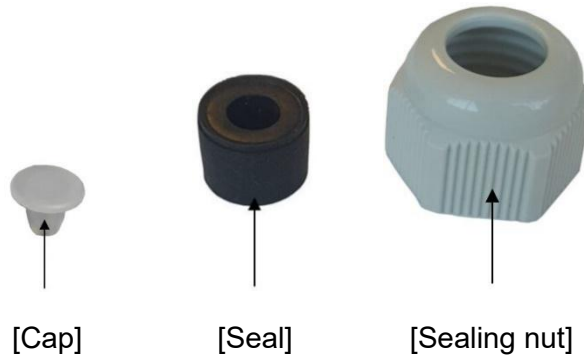

- Cap to close the cable gland input which will not be use.
- Seal Consisting of two concentric rubber rings to seal the cable introduced through the cable gland input.
- Sealing nut to close the cable gland input.

NOTE: If only one of the two inputs cable gland is used, place the supplied cap on the unused input to maintain IP65 sensor protection.

Follow these steps to enter the power and / or communication cables in the corresponding input cable glands:

- 1) If there is a cap, remove it and then unscrew the sealing nut.
- 2) Pass the power / communication cable through the corresponding input cable gland. If the thickness of the cable does not allow to insert the cable, push the Seal part with a thin and elongated tool by pushing from the inside of the *TA150* central body [3].

Once the Seal is removed, separate the two concentric rubber rings and insert just the external rubber ring from the outside of the *TA150* central body [3].



WARNING: When routing the power cable, exercise extreme caution to ensure the cables do not touch each other. It is recommended to individually cover each cable with insulating tape until the connector is attached. Be careful with this connection as you are working with remarkably high voltages, which can be extremely dangerous. Completely avoid touching any metal part of the connector once the cable is in place. Ensure the cable is properly positioned and securely attached to the connector.

- 3) Insert the cable first through the sealing nut and then through the input gland. The cable should not have the connector due the connection between the cable and its connector will be done after the cable is entered through the input cable gland.



- 4) Finally, place the respective connector to the cable which has been introduced through the input cable gland and plug it in the connector on the main body of TA150 sensor.



Power supply for the TA150 | 5

Depending on the configuration of the purchased model, there are several options to power the TA150 sensor:

5.1 Mains power

Connect the power cable to the mains (ensure it meets the specifications described in section 11.11). Take care to place the cable in a "U" shape under the sensor to prevent possible water dripping into the case in case of rain. Refer to chapter 4.2 for more information on passing the cable through the corresponding cable gland input and the precautions to be taken.

Connect the mains cable to the A.C. INPUT of the TA150 sensor [17].

The mains cable must always respect the following cable connections:

- Blue wire Neutral → N
- Yellow and green wire Ground → \perp
- Brown wire Phase → L

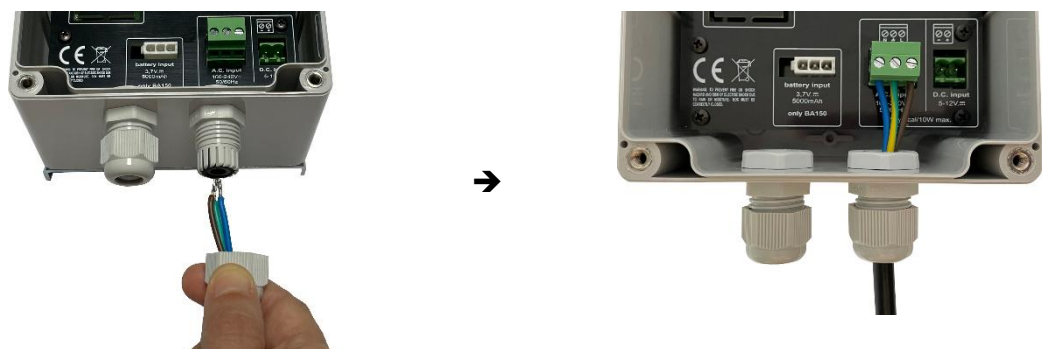

The equivalence of each of the three input connectors of the AC INPUT is indicated on the same label of the TA150 sensor [15].

5.2 5-12VDC Input

Connect the power cable to the 5-12V source (external batteries, etc.). Refer to chapter 4.2 for more information on passing the cable through the corresponding gland input. Connect the mains cable to the D.C. INPUT [16].



IMPORTANT: The length of the power cable connected to the 5-12 VDC input must not exceed 3 metres.

5.3 PoE (Power Over Ethernet)

Uninterrupted power supply through the Ethernet cable. Refer to chapter 4.2 for more information on passing the cable through the corresponding gland input. Connect the Ethernet cable to the LAN input [7].



5.4 BA150* and BA151* Battery (optional)

BA150* is an optional internal lithium battery for daytime operation as a backup to the public lighting network. The BA150* battery guarantees sufficient duration and charging times to complete daily cycles.

BA151* is also an optional internal lithium battery but its duration is approximately 5 days.

Place the battery on its respective support [13] using the supplied flanges and connect the outgoing cable to the battery input connector [18], as shown in the following image:



NOTA: Only the BA150* or BA151* battery can be connected to the battery input [18]. The label “only BA150” is displayed next to the battery input [18].

CESVA is not responsible for any issues that may arise from using batteries other than the BA150* or BA151*.

NOTE: The BA150* y BA151* batteries charge while connected to the power supply.

IMPORTANT: The BA150* y BA151* batteries are designed for cycling use (see 11.11). These batteries are intended for charge and discharge cycles. If continuously powered, their lifespan can be significantly reduced (potentially lasting less than 1 year).

Communication of the *TA150* for data transmission

6

The *TA150* sensor has the following hardware modules for communication: an RJ45 Ethernet connector and a Wi-Fi device located internally in the sensor. Additionally, it allows adding an optional hardware module, which can be chosen from 4G Modem + Geolocation* (*MR154*), Current Loop* (4-20mA) (*CL150*), RS-232* (*RS152*), and RS-485* (*RS154*).

NOTE: Only one hardware module can be added.

Depending on the module, there are several options for communication.

On one hand, it allows transmission to an internet platform, and on the other, transmission via an external output. These two types of transmission can be done simultaneously. For example, the *TA150* can be configured to send signals via the current loop* while sending data to a desired internet platform via Wi-Fi.

The corresponding modules for each interface are:

INTERNET PLATFORM INTERFACE MODULES

- Ethernet
- Wi-Fi
- 4G Modem + Geolocation* (*MR154*)

If the *TA150* has the *MR154**, hardware module installed, it will obtain geolocation information, regardless of whether it uses a different interface (Wi-Fi or Ethernet) to send data to the internet.

EXTERNAL OUTPUT INTERFACE MODULES

- Current Loop* 4-20mA (*CL150*)
- RS-232* Serial (*RS152*)
- RS-485* Serial (*RS154*)

6.1 Ethernet

To communicate via the Ethernet module, insert the LAN cable without the RJ45 connector through the lower input cable gland [4], then crimp the connector to the cable. Refer to chapter 4.2 for more information on passing the cable through the corresponding input cable gland.



Connect the LAN cable between the RJ45 connector [7] and the corresponding router or AP (Access Point).

Take care to place the cable in a "U" shape under the *TA150* sensor to prevent possible water dripping into the case in case of rain.

Access the sensor's web server to select the Ethernet interface. Refer to chapter 3.4.

6.2 Wi-Fi

To communicate via the Wi-Fi module, access the sensor's web server to select the Wi-Fi interface and search for the Wi-Fi network to connect the *TA150* sensor. Refer to chapter 3.4.

6.3 4G Modem + Geolocation* (MR154)

To communicate via the 4G modem module*, open the slot [9] by gently pulling the metal cover down (until you hear a click) and outwards. Insert the micro-SIM card, ensuring its position as shown in the images. Close the slot [9] by pushing the metal cover inwards and gently pulling upwards (until you hear a click).



MR154*

Access the sensor's web server to select the Modem interface and configure the parameters of the TA150's MR154* modem. Refer to chapter 3.4.

NOTE: CESVA only recommends using contract SIM cards with a flat rate. Other type of cards, such as prepaid, may cause issues.

CESVA recommends using SIM cards from mobile operators that have their own infrastructure near the TA150 sensor measurement area.

6.4 Current Loop 4-20mA* (optional CL120)

To communicate via the analog output using the current loop* 4-20mA, insert the communication cable through the lower cable gland input [4], then connect the cable to the current loop* 4-20mA connector [9]. Refer to chapter 4.2 for more information on passing the cable through the corresponding cable gland input.

Access the sensor's web server to select the Current Loop* output interface and configure the parameters. Refer to chapter 3.4.

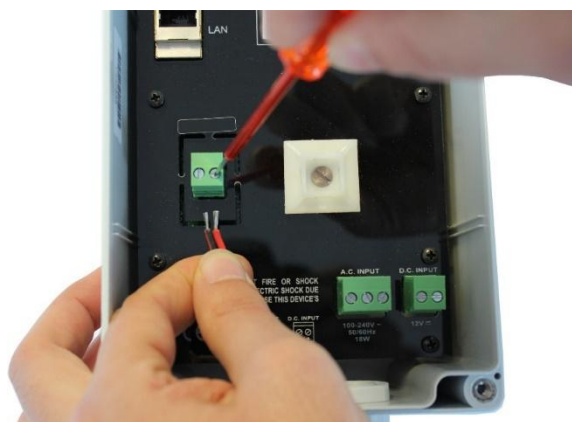

Technical characteristics of this current output:

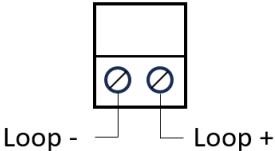
Min. power supply	9 V (between Loop+ and Loop- with 24 mA)
Max. power supply	36 V
Output	4 to 20 mA / 27,4 to 137,0 dBA $I_{out} = \left((L_{AT}) * \frac{20}{137} \right)$ <p>Note 1: I_{out} is the output current in mA Note 2: L_{AT} is the measured level in dBA Note 3: The measurement range is 27,4 to 137,0 dBA Note 4: T is the programmed averaging time. The output current is updated every T^(*). Note 5: If an overload occurs, $I_{out} = 24,0$ mA</p>
Maximum error	± 5 µA
Connection	With polarity 

(*) Configurable parameter via the web server. For more information, see section 3.4.1.1

6.4.1 Description of a 4-20mA current loop* circuit

A typical 4-20mA current loop circuit consists of the following elements: a sensor (*TA150*), a power supply for the loop, and a receiver (to read the information). These elements are connected in series in a closed circuit.

The sensor output transmits a continuous current between 4-20mA proportional to the value measured by the sensor that flows within the closed loop. A current of 4 mA corresponds to the sensor's lowest level output, and a current of 20 mA corresponds to the sensor's highest-level output.

The receiver, usually a data acquisition system, converts the 4-20 mA current into a voltage that can be processed and/or displayed.

Current loops are ideal for data transmission due to their inherent insensitivity to electrical noise. In a 4-20 mA current loop*, all the current flows through all components.

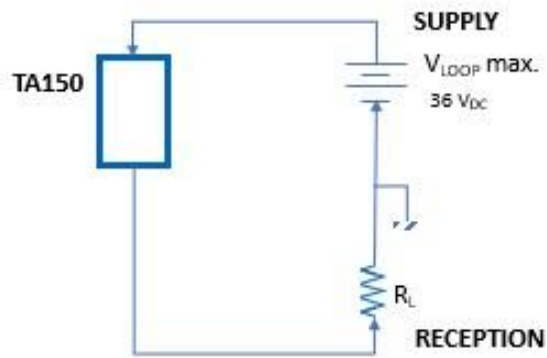

6.5 RS-232* (optional RS152)

To communicate via the RS-232* serial module (RS152), insert the communication cable through the lower cable gland input [4], then connect the cable to the RS-232* connector [9]. Refer to chapter 4.2 for more information on passing the cable through the corresponding cable gland input.

Access the sensor's web server to select the RS-232* output interface and configure the parameters. Refer to chapter 3.4.

For more information about this module, consult the TA150-RS-232 protocol available on the website (www.cesva.com).

6.6 RS-485* (optional RS154)

To communicate via the RS-485* serial module (RS154), insert the communication cable through the lower cable gland input [4], then connect the cable to the RS-485* connector [9]. Refer to chapter 4.2 for more information on passing the cable through the corresponding gland input.

Access the sensor's web server to select the RS-485* output interface and configure the parameters. Refer to chapter 3.4.

For more information about this module, consult the TA150-RS-485 protocol available on the website (www.cesva.com).

Optional firmware modules*

7

The TA150 offers the possibility of expansion with various firmware modules. Section 10.2 explains how to activate one of these modules.

7.1 FR150 module*

NOTE: This module is optional and can be purchased either at the time of buying the TA150 or later. See section 10.2.

The FR150* module is designed to perform spectral measurements with one-third octave band resolution. The TA150 performs a frequency analysis of the continuous equivalent sound pressure level in one-third octave bands from 6.3 Hz to 20 kHz (without frequency weighting). This analysis is conducted in real-time for all bands and across the entire dynamic measurement range (without changing scales), measuring the equivalent level for the integration time T.

TIME BASE	FUNCTIONS
-----------	-----------

T: Programmed Integration Time	L _{fT}
--------------------------------	-----------------

f: indicates the one-third octave band filter with central frequencies of 6.3, 8, 10, 12.5, 16, 20, 25, 31.5, 40, 50, 63, 80, 100, 125, 160, 200, 250, 315, 400, 500, 630, 800, 1000 (1k), 1250 (1.25k), 1600 (1.6k), 2000 (2k), 2500 (2.5k), 3150 (3.15k), 4000 (4k), 5000 (5k), 6300 (6.3k), 8000 (8k), 10000 (10k), 12500 (12.5k), 16000 (16k) and 20000 (20k) Hz. All functions are measured simultaneously with all one-third octave band filters and without frequency weighting.

7.2 GA150 Module*

NOTE: This module is optional and can be purchased either at the time of buying the *TA150* or later. See section 10.2.

The *GA150** module allows obtaining the audio signal acquired by the microphone. This signal can be obtained in three different formats (MP3, FLAC, or WAV) depending on the user's needs.

MP3 and FLAC formats are sent compressed, while WAV format is sent uncompressed. On the other hand, FLAC and WAV formats, as they do not involve quality loss, provide all the necessary information for the user to perform more detailed post-processing if they have suitable software.

To obtain audio files, it is essential that the *TA150* is powered.

The *GA150** module has automatisms and triggers to indicate the start and end of audio acquisition.

To configure all the parameters of the *GA150** module, it must be done via the webserver, see section 3.5.2.

Acoustic verification of the sensor is an effortless process that can be performed by following the steps described below:

8.1 Remove the front cover and TK120 outdoor kit

1. Unscrew the four screws [1] on the front cover. Remove the front cover.



2. Unscrew the lower part of the *TK120* outdoor kit [1] to the right.



3. Once unscrewed, carefully lift the *TK120* outdoor kit [1] until the microphone is visible.



8.2 Place the calibrator

1. Insert the sensor's microphone into the calibrator's hole. Ensure it is fully inserted into the cavity and parallel to the calibrator's axis. It may be a bit difficult as the calibrator must fit perfectly to the microphone. Do not insert the microphone abruptly, as it could be damaged.



2. Turn on the calibrator and check the battery status. The indicator light should remain illuminated throughout the calibration process. The calibrator generates a tone of 94 dB at 1 kHz.



Wait about 10 seconds until the acoustic pressure level generated by the calibrator stabilizes.

8.3 Verify the adjustment

1. Ensure the *TA150* sensor is turned on (if not, power the sensor, see chapter 5).
2. Ensure the mini-OLED screen is turned on (if not, press the [13] button once).
3. To view the level measured by the sensor, there are two ways:
 - Via the sensor's mini-OLED screen: press the [13] button once, and the L_{A1s} level will automatically be displayed on the screen.
 - Via the web server: Access the web server and select the adjustment option (see section 3.1), and the L_{A1s} level will automatically be displayed on the screen.

Perform the actions indicated based on the value displayed on the screen, as described in section 3.3.1.

8.4 Close and secure the sensor

1. Turn off the CESVA calibrator and carefully remove it from the sensor.



2. Carefully insert the *TK120* outdoor kit [1] without damaging the microphone.



3. Once inserted, screw to the left using the base of the kit



4. Finally, close and secure the four screws [1] on the front cover of the *TA150*.

CESVA recommends performing an annual acoustic verification (chapte 8) and a status check of the *TK120* [1] outdoor kit. It is necessary to replace the *PV120* windscreen with a new one and inspect the *TK120* [1] at least once a year. If environmental conditions are severe, this should be done more frequently.

9.1 Replacing the windscreen

To replace the windscreen, it is advisable to first remove the *TK120* outdoor kit. The removal of the outdoor kit is explained in section 9.2.1.

The steps to replace the windscreen are:

1. Unscrew the tip of the *TK120* outdoor kit [1] to the right and lift it upwards.



2. Remove the main part of the foam by pulling upwards, then the remaining part of the foam by pulling downwards until both are completely out.

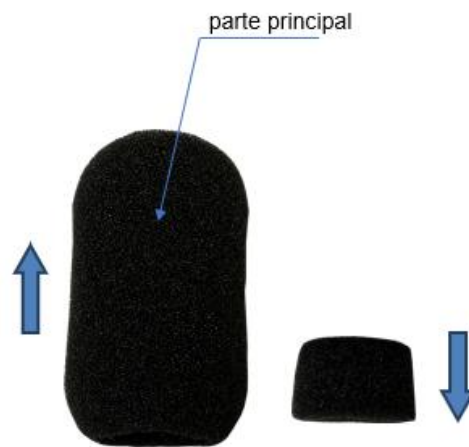

3. Take the main part of the new foam and insert it from the top, aligning the upper hole with the screw of the outdoor kit.

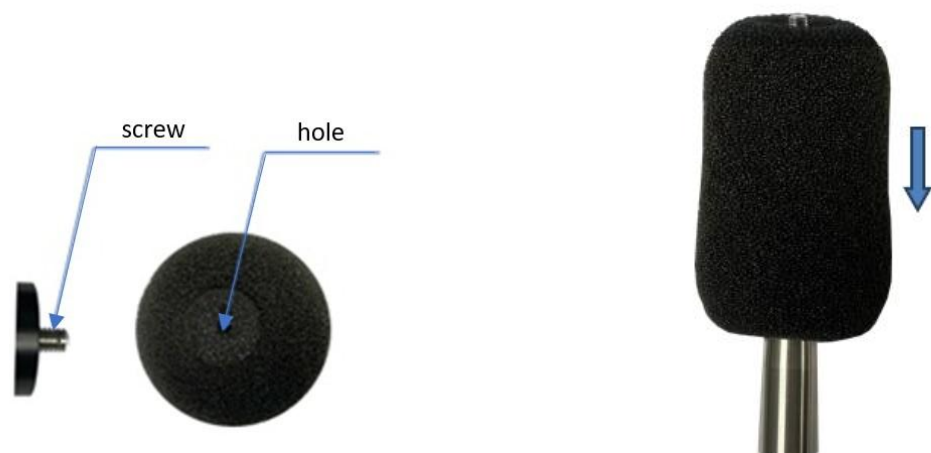

4. Take the cone and screw it onto the thread protruding from the top.



5. Take the other part of the new foam and insert it from the bottom of the outdoor kit.



Ensure it is well inserted into the main part of the foam.



Each time the windscreen is replaced, the *TK120* [1] outdoor kit should be inspected, and if damaged it must be replaced with a new one.

After replacing the windscreen, reattach the outdoor kit to the sensor (see section 9.2.2).

9.2 Replacing the outdoor kit

If the outdoor kit needs to be replaced, acquire a new one and follow these steps:

9.2.1 Removing the outdoor kit

1. Unscrew the lower part of the *TK120* [1] outdoor kit to the right.

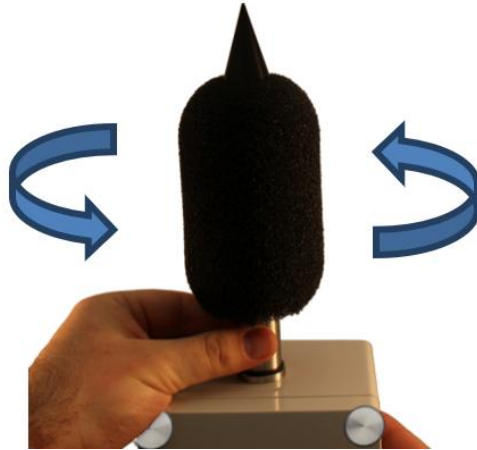

2. Once unscrewed, carefully lift the *TK120* [1] outdoor kit until the microphone is visible. Inspect the microphone and, if necessary, gently remove dust with a fine camel-hair brush.



9.2.2 Installing the outdoor kit

1. Carefully insert the new *TK120* [1] outdoor kit without damaging the microphone.



2. Once inserted, screw to the left using the base of the kit.



We recommend sending the old *TK120* [1] outdoor kit to CESVA facilities for recycling (C/Maracaibo 6, 08030 Barcelona. Tel: 934335240).

If the *TK120* [1] outdoor kit has received any impact or shows any damage, the microphone may be damaged. In this case, we recommend sending the complete sensor to CESVA facilities for technical service to verify the microphone.

The *TA150* offers the possibility to:

- Update the device firmware
- Activate a module for the *TA150*

without needing to send the device to technical service. This saves a significant amount of time and money.

10.1 Firmware update

CESVA recommends keeping the sensor updated to the latest available firmware version.

The sensor automatically updates the firmware version. For the sensor to perform this update, it must be powered and connected to the internet, allowing the sensor to periodically check for new versions.

If the sensor finds a recent version, it automatically updates the firmware. During the process, the following messages are displayed on the mini-OLED screen:

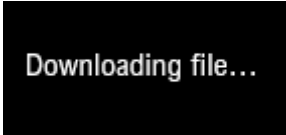

Downloading file...

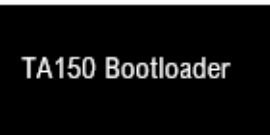

TA150 Bootloader

Once the update process is complete, the sensor resumes normal operation.

NOTE: If there is a new firmware version and you want to force the update, restart the *TA150* (disconnect it from the power supply and reconnect it).

NOTE: Do not turn off the sensor while the firmware is being updated.

NOTE: During the update process, the sensor does not send data to the selected platform.

NOTE: During the update process, the sensor restarts and if there is data in the buffer, it will be erased.

10.2 Activation of an optional TA150 module

Optional modules can be purchased when buying the *TA150* or later. To incorporate them, simply contact your **CESVA** official distributor, provide the serial number of your sensor, and manage the module acquisition procedures.

The sensor automatically activates the module. For the sensor to perform this activation, it must be powered and connected to the internet.

Once the activation process is complete, the sensor resumes normal operation.

Currently available optional modules:

*FR150**: One-third octave band spectral analysis module (1/3)

*GA150**: Audio acquisition

This chapter contains the technical specifications of the **CESVA TA150** sensor.

11.1 REFERENCE CONDITIONS

REFERENCE DIRECTION:	Perpendicular to the microphone diaphragm
REFERENCE POINT OF THE MICROPHONE:	Central point of the microphone diaphragm
REFERENCE LEVEL RANGE:	It has single range, and this is the reference
REFERENCE SOUND PRESSURE LEVEL:	94 dB (referred to 20 μ Pa)
REFERENCE FREQUENCY:	1 kHz
REFERENCE TEMPERATURE:	23 °C
REFERENCE RELATIVE HUMIDITY:	50 %
REFERENCE ATMOSPHERIC PRESSURE:	101.325 kPa

11.2 ACOUSTIC MEASUREMENT ACCORDING TO IEC 61672-1

DETECTOR:	Equivalent continuous sound pressure level, Sound pressure level with fast, slow, or impulse time weighting Peak sound pressure level
FREQUENCY WEIGHTINGS	A, C and Z

MEASURED ACOUSTIC FUNCTIONS:	Equivalent levels with A, C and Z frequency weighting with programmable time between 1s and 60min: LAT, LCT, LZT
	Equivalent level with impulse time weighting over a programmable time between 1s and 60min and A frequency weighting: LAIT
	Maximum levels with fast, slow, and impulse time weighting over a programmable time between 1s and 60min and A frequency weighting: LAFmaxT, LASmaxT, LAImaxT
	Peak level with A and Z frequency weighting with programmable time between 1s and 60min: LCpeakT, LZpeakT
	Percentile levels: L10T, L50T, L90T

NOTE: T values < 10s require fast connection speeds

RESOLUTION:	0.1 dB
ACCURACY according to IEC 61672-1:	Class 1
FILTER ACCURACY according to IEC 61260-1:	Class 1
ACOUSTIC VERIFICATION	with acoustic calibrator (IEC 60942)

LF, LS, LI, LIT and LT FUNCTIONS

MEASUREMENT RANGE single range, from noise level:	25.5 to 137.0 dBA
LINEARITY RANGE at 1kHz:	30.5 to 137.0 dBA
MEASUREMENT RANGE single range, from noise level:	29.1 to 137.0 dBC
LINEARITY RANGE at 1kHz:	34.1 to 137.0 dBC
MEASUREMENT RANGE single range, from noise level:	33.3 to 137.0 dBZ
LINEARITY RANGE at 1kHz:	38.3 to 137.0 dBZ

LCpeak i LZpeak FUNCTION

LINEARITY RANGE at 1kHz:	55.0 to 140.0 dBC
LINEARITY RANGE at 1kHz:	55.0 to 140.0 dBZ

11.3 MICROPHONE

TYPE:	½" condenser microphone
POLARISATION:	0 V
NOMINAL SENSITIVITY:	16.0 mV/Pa

11.4 WARM-UP TIME

WARM-UP TIME:	5 s
---------------	-----

11.5 AUDIO ACQUISITION

FORMAT:	MP3, FLAC, WAV file
MAXIMUM FILE DURATION:	1 min

11.6 PROTECTION AGAINST EXTERNAL AGENTS

TK120 OUTDOOR KIT:	Protection against rain, snow, wind, and birds
INGRESS PROTECTION RATING	IP65

11.7 CONNECTIVITY

USB COMMUNICATION for technical service:	TYPE: Digital, complies with USB rev. 2.0 CONNECTOR: USB type B
ETHERNET COMMUNICATION for data transmission:	CONNECTOR: RJ45 CABLE: CAT5E SFTP 4P DATA TRANSFER SPEED: 10/100 Mbps
Wi-Fi COMMUNICATION for data transmission:	2.4GHz WPA2

11.8 OPTIONAL CONNECTIVITY

COMMUNICATION with 4G modem + Geolocation* for data transmission:	Requires optional <i>MR154*</i> module LTE-TDD BANDS: B34, B38, B39, B40, B41 LTE-FDD BANDS: B1, B2, B3, B4, B5, B7, B8, B12, B13, B18, B19, B20, B25, B26, B28, B66 UMTS/HSPA+ BANDS: B1, B2, B4, B5, B6, B8, B19 GSM/GPRS/EDGE BANDS: 850, 900, 1800, 1900 MHz GEOLOCATION: GNSS (GPS, GLONASS and Galileo) SIM CARD SIZE: micro-SIM
ANALOG COMMUNICATION for current loop* (4-20mA)	Requires optional <i>CL150*</i> module
RS-232* SERIAL COMMUNICATION (includes MODBUS) for data transmission:	Requires optional <i>RS152*</i> module SPEED: Maximum 115200 bps PARITY: Even, odd or none STOP BITS: 1, 1.5 or 2 FLOW CONTROL: None, CTS, RTS or CTS and RTS
RS-485* SERIAL COMMUNICATION (includes MODBUS (2-wire / 4-wire)) for data transmission:	Requires optional <i>RS154*</i> module SPEED: Max. 115200 bps PARITY: Even, odd or none STOP BITS: 1, 1.5 or 2

11.9 TRANSMISSION PROTOCOLS

PROTOCOL:	HTTP, HTTPS (secure connection), MQTT and MQTTS
IP ADDRESS:	Dynamic (DHCP) and Static
PLATFORM:	Sentilo, JSON, UltraLight 2.0, Others (consult)

NOTE: For more information on transmission protocols, please refer to the support section at www.cesva.com.

11.10 REMOTE CONTROL

FEATURES:	Remote sensor configuration Automatic firmware update
-----------	--

11.11 POWER SUPPLY

AC INPUT:		
	Minimum voltage	100V 50/60 Hz
	Maximum voltage	240V 50/60 Hz
	Typical consumption	1 W
	Maximum consumption	10 W
Outdoor cable hose with phase, neutral, and earth, conductor section > 0.75mm ² . Use of RV-K 0.6/1kV 3G1.5 cable is recommended.		
PoE (Power Over Ethernet):	Uninterrupted power supply through the Ethernet cable. Complies with IEEE802.3af	
DC INPUT:		
	Minimum voltage	5 V
	Maximum voltage	12 V
(without BA150)	Typical consumption	1 W
	Maximum consumption	2 W
(with BA150)	Typical consumption	1 W
	Maximum consumption (while charging BA150*)	10 W
The length of the power cable connected to the 5-12 VDC input can be a maximum of 3 meters.		
BATTERY INPUT:	Exclusive power supply through the optional BA150 or BA151*	
PUBLIC LIGHTING NETWORK: Requires BA150* battery	Power supply from public lighting with battery backup.	

NOTE: The typical lifespan of the BA150* and BA151* batteries is 2 years, maintaining a minimum charge of 15%. The number of charge cycles is 750 at 60% capacity.

It is recommended to inspect the BA150* and BA151* batteries after two years of use.

The BA150* and BA151* batteries are designed for cyclic use. These batteries are intended for charge and discharge cycles. If continuously powered, their lifespan can be significantly reduced (potentially lasting less than 1 year).



11.12 ENVIRONMENTAL CRITERIA

TEMPERATURE:	
Acoustic operating range:	-10 to +50 °C
Correct charging and discharging range for BA150* and BA151* batteries.	0 to +40 °C
HUMIDITY:	
Correct acoustic operating range:	25 to 90 %
PRESSURE:	85 to 108 kPa

11.13 DIMENSIONS AND WEIGHT

DIMENSIONS:	395 x 120 x 91 mm
WEIGHT:	without battery 960 g with BA150* battery 1060 g with BA151* battery 1285 g

11.14 MARKING

MARK  , WEEE MARK 

11.15 OPTIONS*

MODEL	DESCRIPTION
FR150*	One-third octave band filter analysis module from 6.3 Hz to 20 kHz
GA150*	Audio file acquisition module
MR154*	4G modem + Geolocation
CL150*	Analog output module for current loop
RS152*	RS-232 digital output module for transmission
RS154*	RS-485 digital output module for transmission
BA150*	Internal lithium battery for 24-hour cycles
BA151*	Internal lithium battery for 5-day cycles

The following precautions and warnings should be considered regarding the *TA150*:

- Remember that the preamplifier is not removable. Under no circumstances should you pull on it, as this would cause damage to the equipment.
- The microphone should never be disassembled as this can permanently damage it.
- Keep the microphone away from dust and sharp objects.
- **WARNING:** Regarding the sensor's power connection, take utmost care to ensure the cables do not touch each other. It is recommended to cover each cable separately with insulating tape until the connector is attached. Be careful with this connection as you are working with remarkably high voltages that can be dangerous. Completely avoid touching any metal part of the connector once the cable is attached. Ensure the cable is properly placed and fixed to the connector.
- Ensure no liquid enters while the sensor cover is open.
- An annual acoustic verification is required as indicated in chapter 8 of this manual.
- It is also necessary to replace the *PV120* windscreen with a new one at least once a year. If environmental conditions are severe, it should be renewed more frequently. Each time the windscreen is replaced, the *TK120* outdoor kit [1] should be inspected.
- The *TA150* sensor is built to be used with great reliability for a long time. If any operational anomaly is not resolved by consulting the manual, send the sensor to an official **CESVA** service. Under no circumstances attempt repairs by unauthorized personnel.
- Use the *TA150* only for the purpose for which it was designed; if the user operates the equipment in an unspecified manner, it could damage the equipment.
- **CESVA** is not responsible for manipulations conducted by unauthorized personnel, thus voiding the warranty.
- This equipment can only work with the **CESVA** accessories mentioned in this manual. If a different accessory is used and it causes a failure in the equipment, **CESVA** is not responsible for this failure, thus voiding the warranty.



Maracaibo, 6 • 08030 Barcelona (España)

Tel. (+34) 934 335 240

info@cesva.com • www.cesva.com

CESVA
instruments, s.l.u. reserves the right to modify the characteristics and accessories of this manual without prior notice.